

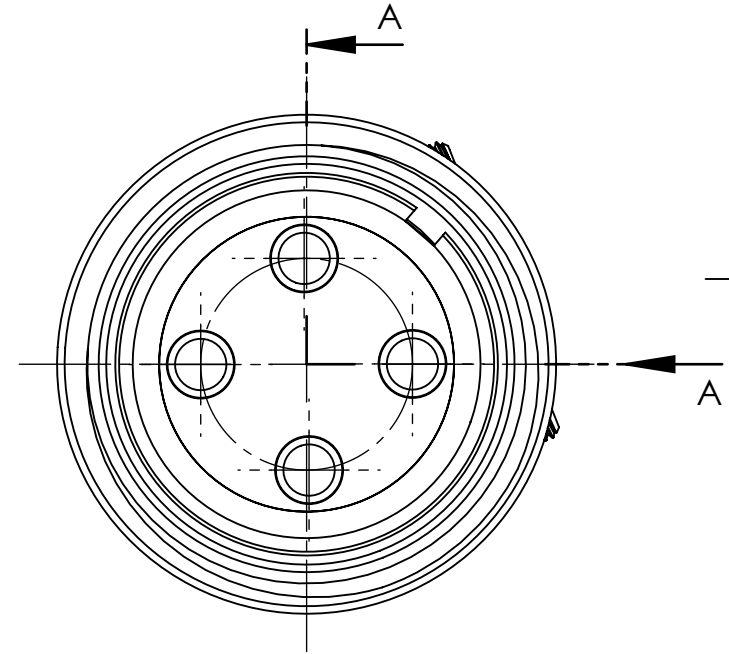

NO	PAT. NO	NAME	MATL.	QTY	TREAT	REMARK
1	H-3004-PMA	BODY	Zn ALLOY	1	M-Cr	---
2	H-3004-PMB-R	INSULATOR	BAKELITE	1	---	BLACK
3	C-3002-PA	BODY	Zn ALLOY	1	M-Cr	---
4	C-3002-PB	CLAMB	Zn ALLOY	1	M-Cr	---
5	C-3002-PF	CAP	Zn ALLOY	1	M-Cr	---
6	C-3002-PG	RUBBER	P.P	1	---	---
7	C-3002-PH-R	SCREW	BRASS	2	M-Ni	---

NO	ELECTRICAL CHARACTERISTICS	
1	Rated current/voltage	15A 250V
2	Operation limit voltage (AC.V.rms)	400
3	Withstanding voltage (AC.V.rms) 1 minute	2000
4	Insulation resistance (MΩ MIN.) at DC 500V	2000
5	Contact resistance (mΩ MAX.) at DC 1A	3

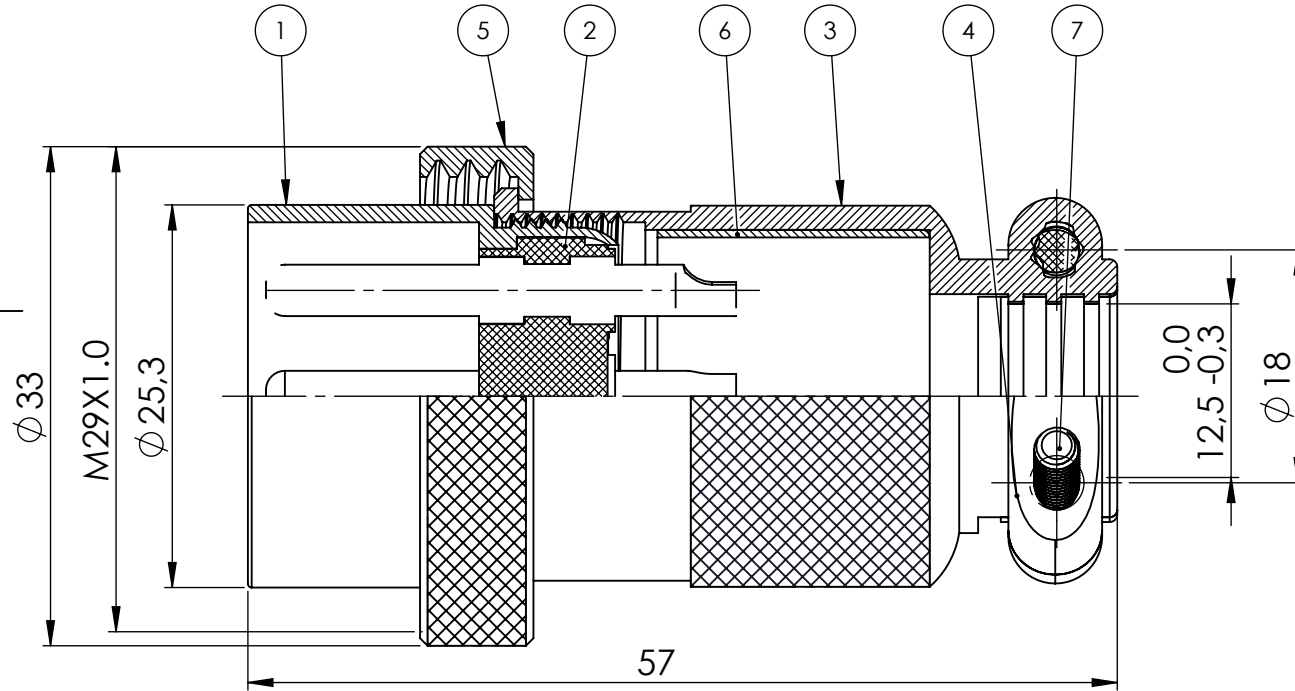

SECTION A-A

NAME	DATE	ARTICLE NO:	REVISION:	TITLE:
DRAWN Halit Yılmaz				
CHECKED Ahmet Altınışık		COMMENTS:		
 www.altinkaya.com.tr		This drawing is subject to technical modification without prior notice. Typographical and other errors do not justify any claims for damages. All dimensions should be verified using an actual produced part.		
PROPRIETARY AND CONFIDENTIAL THE INFORMATION CONTAINED IN THIS DRAWING IS THE SOLE PROPERTY OF ALTINKAYA ENCLOSURES. ANY REPRODUCTION IN PART OR AS A WHOLE WITHOUT THE WRITTEN PERMISSION OF ALTINKAYA ENCLOSURES IS PROHIBITED.		DİKKAT: BU RESİM VE ÜRÜN ÖNCEDEN HABER VERİLMEKSİZİN DEĞİŞTİRİLEBİLİR. RESİM ÇİZİLRKEN HATASIZ OLMASINA ÇALIŞILMASINA RAĞMEN RESİMDE HATALAR BULUNABİLİR. RESİMDEKİ HATALARDAN DOLAYI OLUŞABİLECEK ZARARLAR İÇİN ALTINKAYA HİÇ BİR SORUMLULUK KABUL ETMEZ. BÜTÜN ÖLÇÜLER KULLANILMADAN ÖNCE ÜRETİLMİŞ GERÇEK NUMUNEDEN KONTROL EDİLMELİDİR.		DWG NO: PLT-304-PM-R
MATERIAL:		WEIGHT:	SCALE:1:1	SHEET 1 OF 1

A4

